



# HEALTHY FOOD PROCESSING CO.

**OUR REACH IS BOUNDLESS**

We supply to both domestic and international markets.

# INDEX

Our Healthy Range

01-08

Millets & Millet Recipes

09-10

RTC & RTE Range

11

High Protein Bar

12

About The Plant

13

# OUR HEALTHY RANGE

150+ PRODUCTS

## RAW MATERIALS

- Pulses
- Spices, Condiments, Blends & Masalas
- Rice
- Flours
- Sweeteners
- Super Foods
- Dry Fruits
- Oil Seeds
- Ghee
- Edible Cold Pressed Oils
- Herbs
- Salts

## VALUE ADDED PRODUCTS

- Speciality Flours
- Millet & Millet Flours
- Millet Roasted Porridges
- Millet Ready-To-Cook Premixes
- Ready-To-Eat Snacks
- High Protein Bars
- Blended Spices

# PULSES...

- ✓ Green Gram Whole
- ✓ Green Gram Split With Skin
- ✓ Green Gram Split Without Skin
- ✓ Dew Gram Whole / Haricot Beans
- ✓ Black Gram Whole
- ✓ Black Gram Split With Skin
- ✓ Black Gram Split Without Skin
- ✓ Pink Lentil Whole
- ✓ Pink Lentil Whole Without Skin
- ✓ Pink Lentil Split Without Skin
- ✓ Bengal Gram
- ✓ Brown Chickpeas
- ✓ Chickpeas
- ✓ Pigeon Peas
- ✓ Cowpea White Whole
- ✓ Cowpea Split
- ✓ Red Kidney Beans
- ✓ Speckled Kidney Beans
- ✓ Himalayan Kidney Beans
- ✓ Mix Dal





# SPICES, CONDIMENTS, BLENDS & MASALAS...

- ✓ Fenugreek
- ✓ Fenugreek Powder
- ✓ Carom Seeds
- ✓ Carom Seeds Powder
- ✓ Yellow Mustard Seeds
- ✓ Cumin
- ✓ Cumin Powder
- ✓ Fennel
- ✓ Fennel Powder
- ✓ Coriander Seed
- ✓ Coriander Powder
- ✓ Red Chilli Whole
- ✓ Red Chilli Flakes
- ✓ Red Chilli Powder
- ✓ Kashmiri Red Chilli Powder
- ✓ Dry Mango Powder
- ✓ Black Pepper
- ✓ Black Pepper Powder
- ✓ Green Cardamom
- ✓ Green Cardamom Powder
- ✓ Cinnamon Quills
- ✓ Cinnamon Bark
- ✓ Cinnamon Powder
- ✓ Clove
- ✓ Clove Powder
- ✓ Nigella Seeds
- ✓ Bay Leaf
- ✓ Nutmeg
- ✓ Nutmeg Powder
- ✓ Mace
- ✓ Saffron (Full Thread)
- ✓ Garam Masala
- ✓ Asafoetida
- ✓ Lemon Powder
- ✓ Onion Powder
- ✓ Tomato Powder
- ✓ Green Chilli Powder
- ✓ Kasuri Methi
- ✓ Mint Powder
- ✓ Curry Masala
- ✓ Curry Leaves
- ✓ Curry Leaves Powder
- ✓ Ginger Powder
- ✓ Garlic Powder
- ✓ Black Cardamom
- ✓ Black Cardamom Powder



# RICE...

- ✓ Basmati White Rice
- ✓ Basmati Brown Rice
- ✓ Sonamasuri Brown
- ✓ Sonamasuri White
- ✓ Broken Rice
- ✓ Red Rice
- ✓ Black Rice
- ✓ Rice Flakes
- ✓ Red Rice Flakes
- ✓ Puffed Rice
- ✓ Idli Rice

# FLOURS...

- |                        |   |
|------------------------|---|
| ✓ Amaranth Flour       | ✓ Brown Rice Flour                          |
| ✓ Barley Flour         | ✓ White Rice Flour                          |
| ✓ Gram Flour           | ✓ Red Rice Flour                            |
| ✓ Oats Flour           | ✓ Moong Flour                               |
| ✓ Buckwheat Flour      | ✓ Chickpea Flour                            |
| ✓ Maize Flour          | ✓ Black Wheat Flour                         |
| ✓ Semolina             | ✓ Wheat Flour                               |
| ✓ Moong Flour          | ✓ Khapli Wheat Flour                        |
| ✓ Black Gram Flour     | ✓ Refined Wheat Flour/<br>All Purpose Flour |
| ✓ Brown Chickpea Flour |   |

## SPECIALITY FLOURS

- |                           |                       |
|---------------------------|-----------------------|
| ✓ Multigrain Flour        | ✓ Probiotic Flour     |
| ✓ Hi-Protein Flour        | ✓ High Curcumin Flour |
| ✓ Diabetes-Friendly Flour |                       |



# HERBS...



- ✓ Withania Somnifera (Ashwagandha)
- ✓ Centella Asiatica (Gotu Kola )
- ✓ Hibiscus Rosa-Sinensis (Orhul)
- ✓ Stevia Rebaudiana (Sugarleaf)
- ✓ Ocimum Tenuiflorum (Tulsi Krishna)
- ✓ Hemidesmus Indicus (Anantmool)
- ✓ Beta Vulgaris (Beet Root)
- ✓ Triticum Aestivum Linn (Wheatgrass)
- ✓ Rosa Rubiginosa (Rose)
- ✓ Cassia Angustifolia (Sonamukhi Leaves)
- ✓ Emblica Officinalis (Triphala)
- ✓ Citrus Limon (Lemon Peel)
- ✓ Momordica Charantia (Bitter Melon)
- ✓ Saraca Asoca (Ashoka Bark)
- ✓ Convolvulus Pluricaulis (Shankhpushpi)
- ✓ Tribulus Terrestris (Gokshura)
- ✓ Zingiber Officinale (Ginger)
- ✓ Elettaria Cardamomum (Cardamom)
- ✓ Stevia Rebaudiana (Stevia)
- ✓ Senna Alexandrina (Senna)
- ✓ Cinnamomum Verum (Cinnamon)
- ✓ Acacia Concinna (Shikakai)
- ✓ Citrus Aurantium Dulcis (Orange Peel)
- ✓ Terminalia Arjuna (Arjuna Bark)
- ✓ Terminalia Chebula (Harad)
- ✓ Tinospora Cordifolia (Giloy)
- ✓ Azadirachta Indica (Neem)
- ✓ Cichorium Intybus (Chicory)
- ✓ Chlorophytum Borivillianum (Musli)
- ✓ Moringa Oleifera (Moringa)
- ✓ Asparagus Racemosus (Shatavari)
- ✓ Indian Gooseberry (Amla)
- ✓ Aloe Barbadensis Miller (Aloe Vera)
- ✓ Glycyrrhiza Glabra (Licorice)
- ✓ Terminalia Chebula (Haritaki)
- ✓ Cymbopogon Citratus (Lemon Grass)
- ✓ Curcuma Longa (Turmeric)
- ✓ Turmeric Pods
- ✓ Hibiscus Rosa-Sinensis (Hibiscus)



Powdered



Cut & Sifted



Granular



TBC

# SUPER FOODS...

- ✓ Flax Seeds
- ✓ Quinoa
- ✓ Chia Seeds
- ✓ Pumpkin Seeds
- ✓ Sunflower Seeds
- ✓ Psyllium Husk
- ✓ Seed Mix



# DRY FRUITS...

- ✓ Almonds
- ✓ Cashew
- ✓ Raisin
- ✓ Walnuts



# SWEETENERS...

- ✓ Honey
- ✓ Desi Khand - White
- ✓ Desi Khand - Brown
- ✓ Brown Sugar
- ✓ White Sugar
- ✓ Jaggery
- ✓ Jaggery Powder
- ✓ Jaggery Syrup



# BLENDED SPICES...

- ✓ Biryani Masala
- ✓ Shahi Paneer Masala
- ✓ Pav Bhaji Masala
- ✓ Kitchen King Masala
- ✓ Sambhar Masala
- ✓ Chole Masala
- ✓ Chaat Masala
- ✓ Chicken Masala
- ✓ Garam Masala
- ✓ Curry Masala
- ✓ Halim Masala
- ✓ Meat Masala
- ✓ Jeeravan Masala
- ✓ Tea Masala
- ✓ Jain Kitchen King
- ✓ Tandoori Marination Masala
- ✓ Tikka Masala Rub
- ✓ Sea Food Masala
- ✓ Fish Curry Masala



# GHEE...

- ✓ Curd Based Bilona Cow Ghee
- ✓ Curd Based Bilona Desi Cow Ghee



## OIL SEEDS...

- ✓ Mustard Seeds
- ✓ Sesame Seeds Hulled
- ✓ Sesame Seeds Natural - White
- ✓ Sesame Seeds Natural - Black



## EDIBLE COLD PRESSED OILS...

- ✓ Groundnut Oil
- ✓ Mustard Oil
- ✓ White Sesame Oil
- ✓ Black Sesame Oil
- ✓ Sunflower Oil
- ✓ Soybean Oil
- ✓ Coconut Oil
- ✓ Castor Oil

## SALTS...

- ✓ Rock Salt
- ✓ Black Salt
- ✓ Himalayan Pink Salt
- ✓ Normal Salt



# MILLETS & WHOLE GRAINS...

- ✓ Brown Top Millet
- ✓ Finger Millet
- ✓ Kodo Millet
- ✓ Barnyard Millet
- ✓ Proso Millet
- ✓ Foxtail Millet
- ✓ Pearl Millet
- ✓ Little Millet
- ✓ Sorghum Millet
- ✓ Amaranth
- ✓ Buckwheat
- ✓ Maize
- ✓ Oats
- ✓ Black Wheat Grain
- ✓ Wheat Grain
- ✓ Wheat Bran
- ✓ Khapli Wheat

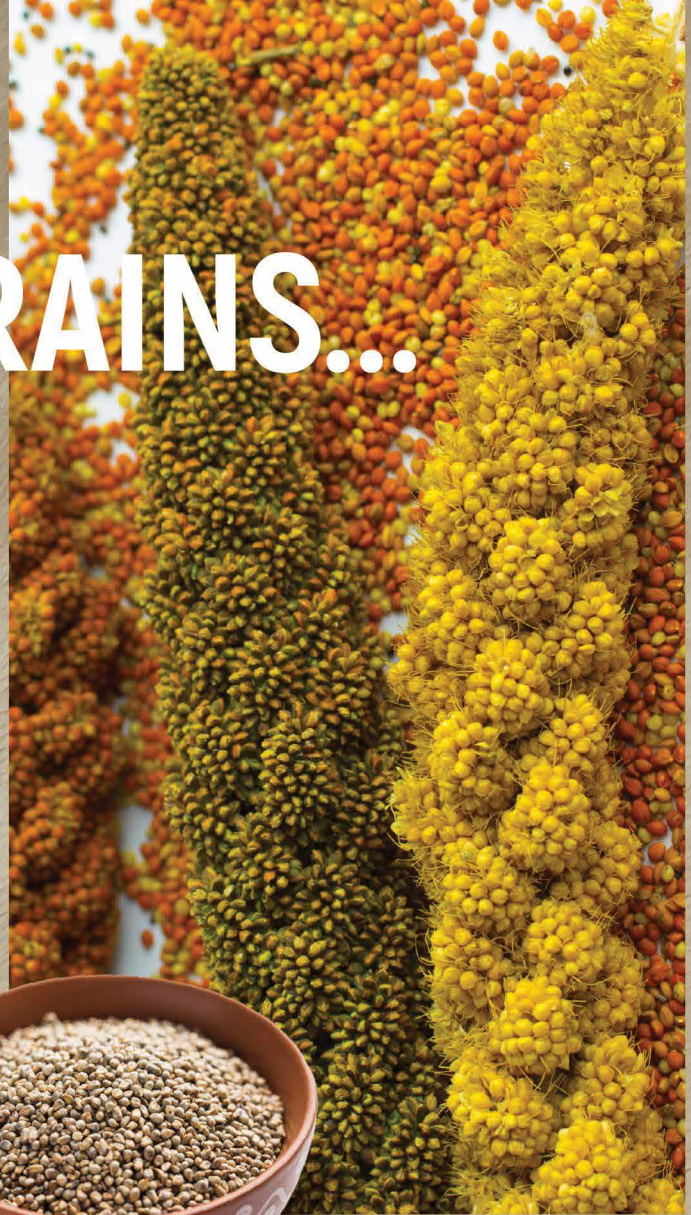

# MILLET FLOURS...

- ✓ Pearl Millet Flour (Bajra)
- ✓ Sorghum Flour (Jowar)
- ✓ Finger Millet Flour (Ragi)
- ✓ Kodo Millet Flour
- ✓ Brown Top Millet Flour
- ✓ Proso Millet Flour
- ✓ Foxtail Millet Flour
- ✓ Little Millet Flour
- ✓ Barnyard Flour





# ROASTED PORRIDGES...

- ✓ Ragi Millet Porridge
- ✓ Kodo Millet Porridge
- ✓ Foxtail Millet Porridge
- ✓ Proso Millet Porridge
- ✓ Little Millet Porridge
- ✓ Bajra Porridge
- ✓ Jowar Porridge
- ✓ Multigrain Porridge
- ✓ Black Wheat Porridge
- ✓ Wheat Porridge
- ✓ Maize Porridge



# MILLET READY-TO-COOK PREMIXES...

- ✓ Millet Soup Premix
- ✓ Millet Idli Premix
- ✓ Millet Cheela Premix
- ✓ Millet Kheer Premix
- ✓ Millet Pankcake Premix

# READY-TO-COOK PREMIXES RANGE...

- ✓ Instant Moong Halwa
- ✓ Multigrain Cheela Mix
- ✓ Oats Cheela Mix
- ✓ Millet Cheela Mix
- ✓ Instant Millet Soup Mix
- ✓ Instant Millet Idli Mix
- ✓ Instant Pancake Mix
- ✓ Instant Bedmi Poori Mix
- ✓ Instant High Protein Upma
- ✓ Instant Khaman Dhokla
- ✓ Instant Thandai
- ✓ Instant Savoury Sattu Premix
- ✓ Instant Sattu Soup Premix
- ✓ Instant Thepla Premix
- ✓ Millet Kheer Premix
- ✓ Tomato Chutney (South Indian) Premix
- ✓ Coconut Chutney Premix
- ✓ Instant Bhatura Mix
- ✓ Instant Bhakari Mix
- ✓ Sattu Protein Shakes Premix  
(Vanilla | Hazelnut & Coffee | Green Cardamom | Kesar Pista)



# READY-TO-EAT SNACKS...

- ✓ Gur Chana
- ✓ Roasted Chana Jor Garam
- ✓ Roasted Navratan Mix
- ✓ Roasted Lentil Seeds Mix
- ✓ Mini Millet Nan Khatai
- ✓ Mini Millet Jowar Cookies
- ✓ Ragi Ladoo
- ✓ Sattu Ladoo
- ✓ Bajra Ladoo
- ✓ Bajra Cookies
- ✓ Roasted Almonds
- ✓ Roasted Cashews
- ✓ Roasted Dry Fruits Trail Mix
- ✓ Raisins
- ✓ Roasted Seed Mix
- ✓ Roasted Pumpkin Seeds
- ✓ Roasted Watermelon Seeds
- ✓ Roasted Flax Seeds
- ✓ Roasted Chia Seeds
- ✓ Baked Gur Papdi
- ✓ Baked Methi Mathri
- ✓ Roasted Jowar Chiwda
- ✓ Baked Sabudana Chips

# HIGH PROTEIN BARS...

ENDLESS POSSIBILITIES OF FORMULATIONS

- ✓ Vegan
- ✓ Nut Based
- ✓ Seed Based
- ✓ Nut & Seed Based
- ✓ Millet Based
- ✓ Hemp Based
- ✓ Peanut Butter Based
- ✓ Almond Butter Based
- ✓ Oats Based
- ✓ Dates Based
- ✓ Granola Bars



Customizable Options Available in Size, Flavor and Shape



# CHIKKI...

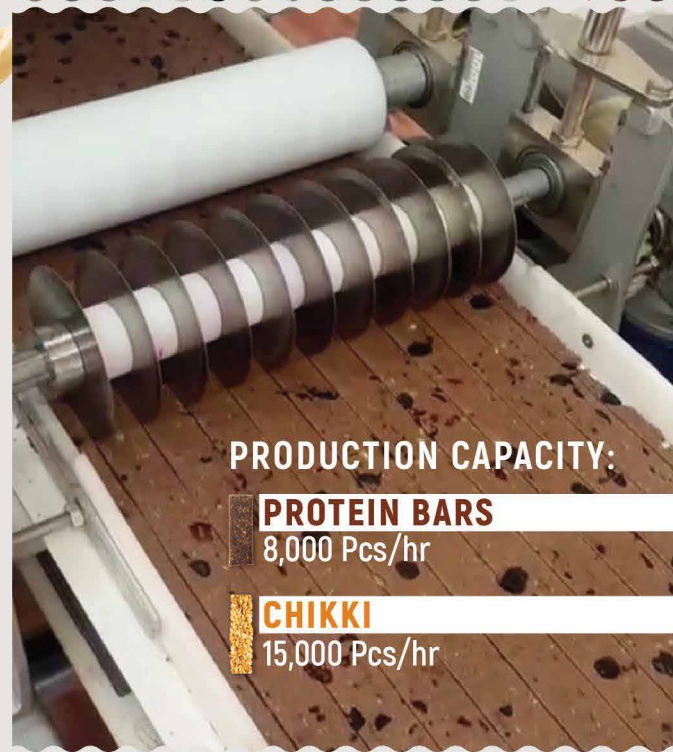
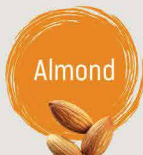
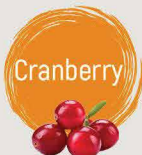

PRODUCTION CAPACITY:

**PROTEIN BARS**  
8,000 Pcs/hr

**CHIKKI**  
15,000 Pcs/hr

# ABOUT THE PLANT..

**INDUSTRY:**  
Healthy Food

**PRODUCTION CAPACITY  
PER MONTH:**  
1000+ Metric Tonnes

**PLANT LOCATION:**  
Jaipur, Rajasthan, India

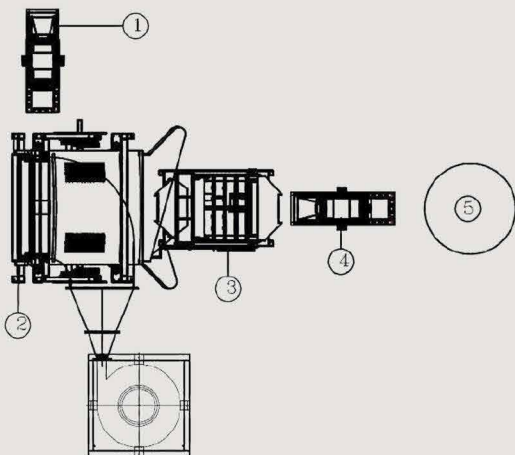
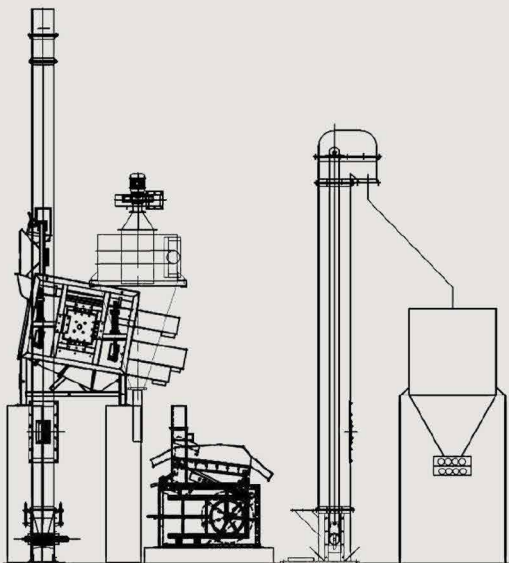



**Manufactured by:**

**M/S Samasta Foods Pvt. Ltd.**

Plot no.113 - 114 Solitaire Industrial Park, Ajmer Road, Jaipur, Rajasthan - 303 007.

*fssai*

Lic No: 12221999000062

**Marketed by:**

**Soul SSpice LLP**

Corporate Office: 273, Shahid Bhagat Singh Road, 2nd Floor, Office no. 19, Fort, Mumbai - 400 001.

In case of any consumer feedback, queries, or complaints. Please write to us at the address mentioned above or  
Email: [feedback@kenkosnax.in](mailto:feedback@kenkosnax.in) or call on +91 9987871462

*fssai*

Lic No: 11525997000299

**Distributed by:**

**SHROFF INC.**

Shop No. 3024, First Floor, Eaze Zone Mall, Off Link Road, Goregaon West, Mumbai - 400 104.

**GST: 27AMVPS7521D3ZJ**